

USER MANUAL

Pellet Stove



©2019 CADEL srl | All rights reserved - Tutti i diritti riservati

**INDIGO - VERA - ELANE - MADISON - TABLA -
ROXY - ATRIUM - SOLO 5**

TECHNICAL DOCUMENTATION FOR LOCAL SPACE HEATERS ACCORDING TO COMMISSION REGULATIONS (EU) 2015/1185 - (EU) 2015/1186 (PRODUCT FICHE)

Manufacturer	CADEL srl - Via Foresto Sud 7 - 31025 Santa Lucia di Piave (TV) - Italy		
Trademark: model identifier	CADEL: SPIRIT3 5kW FREEPOINT: ATRIUM 5 AIRTIGHT PEGASO: SOLO 5 - MADISON 5		
Description	Pellet stove		
Indirect heating functionality	No		
Direct heat output	5,2 kW		
Indirect heat output	- kW		
CPR harmonised standard	EN 14785		
Notified body	IMQ Spa (N.B.0051)		
Preferred fuel (unique)	Compressed wood with moisture content < 12 %	YES	
	Wood logs with moisture content ≤ 25 %	NO	
	Other woody biomass	NO	
Energy efficiency Class (A++ to G scale)	85	%	
	125	-	
Space heating emissions at nominal heat output	PM (at 13% O ₂)	17	mg/Nm ³
	OGC (at 13% O ₂)	4	mg/Nm ³
	CO (at 13% O ₂)	141	mg/Nm ³
	NO _x (at 13% O ₂)	123	mg/Nm ³
Space heating emissions at minimum heat output <i>Only required if correction factors F(2) or F(3) are applied</i>	PM (at 13% O ₂)	20	mg/Nm ³
	OGC (at 13% O ₂)	7	mg/Nm ³
	CO (at 13% O ₂)	235	mg/Nm ³
	NO _x (at 13% O ₂)	121	mg/Nm ³
Heat output	Nominal heat output (P _{nom})	5,2	kW
	Minimum heat output (indicative) (P _{min})	2,5	kW
Useful efficiency (NCV as received)	Useful efficiency at nominal heat output (η _{th, nom})	89,5	%
	Useful efficiency at minimum heat output (indicative) (η _{th, min})	91,5	%
Auxiliary electricity consumption	At nominal heat output (el _{max})	0,062	kW
	At minimum heat output (el _{min})	0,015	kW
	In standby mode (el _{sb})	0,002	kW
Type of heat output/room temperature control (select one)	Single stage heat output, no room temperature control	NO	
	Two or more manual stages, no room temperature control	NO	
	With mechanic thermostat room temperature control	NO	
	With electronic room temperature control	NO	
	With electronic room temperature control plus day timer	NO	
	With electronic room temperature control plus week timer	YES	
Other control options (multiple selections possible)	Room temperature control, with presence detection	NO	
	Room temperature control, with open window detection	NO	
	With distance control option	NO	
Permanent pilot flame power requirement	Pilot flame power requirement (if applicable) (P _{pilot})	N.A.	kW
Observe the specific precautions for installation, assembly and maintenance indicated in the manual accompanying the product.			
Issue date: 01.12.2021	Legal Representative	CADEL s.r.l. Via Foresto Sud, 7 - 31025 SANTA LUCIA DI PIAVE (TV) Tel. 0438 738869 - Fax 0438 73343 Partita IVA 03202180265 R.E.A. TV 227665 - Reg. Soc. Trib. TV 185949	

89CD220002EN

TECHNICAL DOCUMENTATION FOR LOCAL SPACE HEATERS ACCORDING TO COMMISSION REGULATIONS (EU) 2015/1185 - (EU) 2015/1186 (PRODUCT FICHE)

Manufacturer	CADEL srl - Via Foresto Sud 7 - 31025 Santa Lucia di Piave (TV) - Italy		
Trademark: model identifier	CADEL: GRACE3 FREEPOINT: ROXY PEGASO: TABLA		
Description	Pellet stove		
Indirect heating functionality	No		
Direct heat output	7 kW		
Indirect heat output	- kW		
CPR harmonised standard	EN 14785		
Notified body	IMQ Spa (N.B.0051)		
Preferred fuel (unique)	Compressed wood with moisture content < 12 %	YES	
	Wood logs with moisture content ≤ 25 %	NO	
	Other woody biomass	NO	
Energy Efficiency Class (A++ to G scale)	η _s	85	%
	EEI	126	-
Space heating emissions at nominal heat output	PM (at 13% O ₂)	14	mg/Nm ³
	OGC (at 13% O ₂)	4	mg/Nm ³
	CO (at 13% O ₂)	129	mg/Nm ³
	NO _x (at 13% O ₂)	116	mg/Nm ³
Space heating emissions at minimum heat output <i>Only required if correction factors F(2) or F(3) are applied</i>	PM (at 13% O ₂)	19	mg/Nm ³
	OGC (at 13% O ₂)	7	mg/Nm ³
	CO (at 13% O ₂)	183	mg/Nm ³
	NO _x (at 13% O ₂)	103	mg/Nm ³
Heat output	Nominal heat output (P _{nom})	7	kW
	Minimum heat output (indicative) (P _{min})	2,7	kW
Useful efficiency (NCV as received)	Useful efficiency at nominal heat output (η _{th, nom})	89,5	%
	Useful efficiency at minimum heat output (indicative) (η _{th, min})	93	%
Auxiliary electricity consumption	At nominal heat output (el _{max})	0,072	kW
	At minimum heat output (el _{min})	0,019	kW
	In standby mode (el _{sb})	0,002	kW
Type of heat output/room temperature control (select one)	Single stage heat output, no room temperature control	NO	
	Two or more manual stages, no room temperature control	NO	
	With mechanic thermostat room temperature control	NO	
	With electronic room temperature control	NO	
	With electronic room temperature control plus day timer	NO	
	With electronic room temperature control plus week timer	YES	
Other control options (multiple selections possible)	Room temperature control, with presence detection	NO	
	Room temperature control, with open window detection	NO	
	With distance control option	NO	
Permanent pilot flame power requirement	Pilot flame power requirement (if applicable) (P _{pilot})	N.A.	kW
Observe the specific precautions for installation, assembly and maintenance indicated in the manual accompanying the product.			
Issue date: 15.12.2021	Legal Representative	CADEL s.r.l. Via Foresto Sud, 7 - 31025 SANTA LUCIA DI PIAVE (TV) Tel. 0438 738869 - Fax 0438 73343 Partita IVA 03202180265 R.E.A. TV 227665 - Reg. Soc. Trib. TV 185949	

89CD220013EN

TECHNICAL DOCUMENTATION FOR LOCAL SPACE HEATERS ACCORDING TO COMMISSION REGULATIONS (EU) 2015/1185 - (EU) 2015/1186 (PRODUCT FICHE)

Manufacturer	CADEL srl - Via Foresto Sud 7 - 31025 Santa Lucia di Piave (TV) - Italy		
Trademark: model identifier	CADEL: SWEET3 7.0 - PERLA3 7.0 - CRISTAL 7.0 FREEPOINT: ONE AIRTIGHT - BEAM AIRTIGHT - ACCENT AIRTIGHT - ACCENT K AIRTIGHT - INDIGO EVO 7 PEGASO: VERA 7.0 - LORD7.0		
Description	Pellet stove		
Indirect heating functionality	No		
Direct heat output	7 kW		
Indirect heat output	- kW		
CPR harmonised standard	EN 14785		
Notified body	IMQ Spa (N.B.0051)		
Preferred fuel (unique)	Compressed wood with moisture content < 12 %	YES	
	Wood logs with moisture content ≤ 25 %	NO	
	Other woody biomass	NO	
Energy efficiency class	86	%	
	EEI	126	-
Energy Efficiency Class (A++ to G scale)	A+		
Space heating emissions at nominal heat output	PM (at 13% O ₂)	15	mg/Nm ³
	OGC (at 13% O ₂)	1	mg/Nm ³
	CO (at 13% O ₂)	42	mg/Nm ³
	NO _x (at 13% O ₂)	117	mg/Nm ³
Space heating emissions at minimum heat output <i>Only required if correction factors F(2) or F(3) are applied</i>	PM (at 13% O ₂)	20	mg/Nm ³
	OGC (at 13% O ₂)	4	mg/Nm ³
	CO (at 13% O ₂)	238	mg/Nm ³
	NO _x (at 13% O ₂)	140	mg/Nm ³
Heat output	Nominal heat output (P _{nom})	7	kW
	Minimum heat output (indicative) (P _{min})	2,5	kW
Useful efficiency (NCV as received)	Useful efficiency at nominal heat output (η _{th, nom})	90	%
	Useful efficiency at minimum heat output (indicative) (η _{th, min})	91	%
Auxiliary electricity consumption	At nominal heat output (el _{max})	0,049	kW
	At minimum heat output (el _{min})	0,023	kW
	In standby mode (el _{st})	0,002	kW
Type of heat output/room temperature control (select one)	Single stage heat output, no room temperature control	NO	
	Two or more manual stages, no room temperature control	NO	
	With mechanic thermostat room temperature control	NO	
	With electronic room temperature control	NO	
	With electronic room temperature control plus day timer	NO	
	With electronic room temperature control plus week timer	YES	
Other control options (multiple selections possible)	Room temperature control, with presence detection	NO	
	Room temperature control, with open window detection	NO	
	With distance control option	NO	
Permanent pilot flame power requirement	Pilot flame power requirement (if applicable) (P _{pilot})	N.A.	kW
Observe the specific precautions for installation, assembly and maintenance indicated in the manual accompanying the product.			
Issue date: 01.12.2021	Legal Representative	CADEL s.r.l. Via Foresto Sud, 7 - 31025 SANTA LUCIA DI PIAVE (TV) Tel. 0438 738669 - Fax 0438 73343 Partita IVA 03201180265 R.E.A. TV 227665 - Reg. Soc. Trib. TV 185949	

89CD220009EN





TECHNICAL DOCUMENTATION FOR LOCAL SPACE HEATERS ACCORDING TO COMMISSION REGULATIONS (EU) 2015/1185 - (EU) 2015/1186 (PRODUCT FICHE)

Manufacturer	CADEL srl - Via Foresto Sud 7 - 31025 Santa Lucia di Piave (TV) - Italy		
Trademark: model identifier	CADEL: FREEPOINT: PEGASO: ELANE - VENERE AIRTIGHT - TITANIA AIRTIGHT		
Description	Pellet stove		
Indirect heating functionality	No		
Direct heat output	8,6 kW		
Indirect heat output	- kW		
CPR harmonised standard	EN 14785		
Notified body	KIWA S.p.a.N.0476		
Preferred fuel (unique)	Compressed wood with moisture content < 12 %	YES	
	Wood logs with moisture content ≤ 25 %	NO	
	Other woody biomass	NO	
Energy efficiency class	85	%	
EEI	125	-	
Energy Efficiency Class (A++ to G scale)	A+		
Space heating emissions at nominal heat output	PM (at 13% O ₂)	14	mg/Nm ³
	OGC (at 13% O ₂)	1,5	mg/Nm ³
	CO (at 13% O ₂)	79	mg/Nm ³
	NO _x (at 13% O ₂)	135,7	mg/Nm ³
Space heating emissions at minimum heat output <i>Only required if correction factors F(2) or F(3) are applied</i>	PM (at 13% O ₂)	19,3	mg/Nm ³
	OGC (at 13% O ₂)	3,9	mg/Nm ³
	CO (at 13% O ₂)	274	mg/Nm ³
	NO _x (at 13% O ₂)	104,4	mg/Nm ³
Heat output	Nominal heat output (P _{nom})	8,6	kW
	Minimum heat output (indicative) (P _{min})	2,4	kW
Useful efficiency (NCV as received)	Useful efficiency at nominal heat output (η _{th, nom})	89,1	%
	Useful efficiency at minimum heat output (indicative) (η _{th, min})	92,9	%
Auxiliary electricity consumption	At nominal heat output (el _{max})	0,076	kW
	At minimum heat output (el _{min})	0,012	kW
	In standby mode (el _{st})	0,002	kW
Type of heat output/room temperature control (select one)	Single stage heat output, no room temperature control	NO	
	Two or more manual stages, no room temperature control	NO	
	With mechanic thermostat room temperature control	NO	
	With electronic room temperature control	NO	
	With electronic room temperature control plus day timer	NO	
	With electronic room temperature control plus week timer	YES	
Other control options (multiple selections possible)	Room temperature control, with presence detection	NO	
	Room temperature control, with open window detection	NO	
	With distance control option	NO	
Permanent pilot flame power requirement	Pilot flame power requirement (if applicable) (P _{pilot})	N.A.	kW
Observe the specific precautions for installation, assembly and maintenance indicated in the manual accompanying the product.			
Issue date: 30.11.2021	Legal Representative	CADEL s.r.l. Via Foresto Sud, 7 - 31025 SANTA LUCIA DI PIAVE (TV) Tel. 0438 738669 - Fax 0438 73343 Partita IVA 03201180265 R.E.A. - TV 227665 - Reg. Soc. Trib. TV 185949	

SUMMARY

1	MANUAL SIMBOLOGY	3
2	DEAR CUSTOMER	3
3	CAUTIONS	3
4	SAFETY REQUIREMENTS	4
5	WARRANTY CONDITIONS	5
6	SPARE PARTS	6
7	WARNINGS FOR THE CORRECT DISPOSAL OF THE PRODUCT	6
7.1	INFORMATION FOR MANAGEMENT OF ELECTRIC AND ELECTRONIC APPLIANCE WASTE CONTAINING BATTERIES OR ACCUMULATORS	6
8	WI-FI CONNECTION - BLUETOOTH	7
8.1	NAVEL STAND ALONE	7
9	USE	8
9.1	INTRODUCTION	8
9.2	CONTROL PANEL	9
9.3	USER MENU	11
9.3.1	MENU M1 - CLOCK SETTING	15
9.3.2	MENU M2 - CHRONO SETTING	15
9.3.3	MENU M3 - LANGUAGE SELECTION	18
9.3.4	MENU M4 - STAND-BY	18
9.3.5	MENU M5 - BUZZER	19
9.3.6	MENU M6 - FIRST LOAD	19
9.3.7	MENU M7 - STOVE STATUS.....	19
9.3.8	MENU M8 - ENGINEER SETTINGS.....	19
9.3.9	MENU M9 - PELLET TYPE	20
9.3.10	MENU MA - FLUE TYPE.....	20
9.3.11	MENU MB - EXIT	20
9.4	STOVE SWITCH-ON	20
9.5	FAILED IGNITION	21
9.6	POWER FAILURE	21
9.7	TEMPERATURE SETTING.....	21
9.8	POWER SETTING	21
9.9	SWITCHING OFF	22
9.10	CONNECTION TO THE EXTERNAL THERMOSTAT	22
10	FUEL	22
10.1	FUEL	22
10.2	PELLET SUPPLY	23
10.3	PELLET REFUELLING TIMER.....	23
10.4	VENTILATION	23
10.5	REMOTE CONTROL (OPTIONAL)	24
11	SAFETY DEVICES AND ALARMS	25
11.1	SAFETY DEVICES	25
11.2	PRESSURE SWITCH.....	25
11.3	SMOKE TEMPERATURE PROBE	25
11.4	CONTACT THERMOSTAT IN THE FUEL HOPPER.....	25
11.5	ELECTRICAL SAFETY.....	25
11.6	SMOKE FAN	25
11.7	GEAR MOTOR.....	25
11.8	TEMPORARY POWER CUT.....	25
11.9	FAILED START-UP	25
11.10	BLACKOUT WITH THE BOILER ON	25
11.11	FLUE GAS TEMPERATURE PROBE ALARM.....	26
11.12	FLUE GAS OVERTEMPERATURE ALARM.....	26
11.13	FAULTY FLUE GAS ENCODER ALARM	26
11.14	FAILED IGNITION ALARM	27
11.15	NO PELLET ALARM	27
11.16	THERMAL SAFETY OVERHEATING ALARM	27
11.17	NO NEGATIVE PRESSURE ALARM	27
11.18	ALARM ALERTS	28
11.19	ALARM RESET	30
12	ROUTINE MAINTENANCE	30
12.1	INTRODUCTION	30
12.2	DAILY OR WEEKLY CLEANING PERFORMED BY THE USER 31	
12.3	BEFORE EACH START-UP	31
12.4	HOPPER AND AUGER CLEANING	31
12.5	FUME PIPES ANNUAL CLEANING	32
12.6	GENERAL CLEANING.....	32
12.7	CLEANING OF PAINTED METAL PANELS	32
12.8	GLASS CLEANING	32
13	IN CASE OF ANOMALY	32
13.1	PROBLEM SOLVING	32

1 MANUAL SIMBOLOGY

	USER
	AUTHORISED TECHNICIAN (ONLY to interpret or the Stove-manufacturer or the Authorized Technician of Technical Assistance Service approved by the Stove-manufacturer)
	SPECIALIZED STOVE-REPAIRER
	CAUTION: READ CAREFULLY THE NOTE
	CAUTION: DANGER OR IRREVERSIBLE DAMAGE POSSIBILITY

- The icons with the stylized figures indicates whom the subject dealt in the paragraph is addressed to (between the User and/or the Authorized Technician and/or the Specialized Stove-repairer).
- WARNING symbols indicates an important note.

2 DEAR CUSTOMER

- Our products are designed and manufactured in compliance with European regulations harmonised with Regulation (EU) no. 305/2011 for construction products (EN13240 for wood-burning stoves, EN14785 for pellet-burning appliances, EN13229 for fireplaces/wood-burning inserts and EN 12815 for wood-burning range cookers), with high quality materials and extensive experience in transformation processes. The products also comply with the essential requirements of Directive 2009/125/EC (Eco Design) and, where applicable, Directives 2014/35/EU (Low Voltage), 2014/30/EU (Electromagnetic Compatibility), 2014/53/EU (Radio Frequency), 2011/65/EU (RoHS).
- Read carefully the instruction contained in this manual to obtain the best efficiency.
- This instruction manual is an integral part of the product: make sure it is delivered with the appliance also in case of sold to others. In case of loss please ask a copy to your local Technical Assistance Service.



In Italy biomass system installation below 35 kW must comply with MD 37/08. Every qualified installer who own these requirements, has to issue the certificate of conformity for the installed system ("system" means: stove + chimney + air inlet).

- According to (EU) No. 305/2011 regulation, the " Declaration of Performance" and "Declaration of Conformity" are available online at the web sites:
 - www.cadelsrl.com
 - www.free-point.it
 - www.pegasoheating.com

3 CAUTIONS

- All the pictures carried in this manual are only for indicative and explanatory purpose and could therefore slightly differ from your appliance.
- The referring appliance is those you purchased.
- In case of doubts or difficulties in the comprehension or for problems not described in this manual, please promptly contact your distributor or installer.



- Installation, electrical connection, functional verification and maintenance must only be performed by qualified or authorised personnel.
- Live electrical parts: disconnect the product from the 230V power supply before performing any maintenance operation. Only power the product after completing assembly.
- Special maintenance must only be performed by authorised and qualified personnel.
- All local regulations, including those referring to national European standards, must be respected during appliance installation.
- The manufacturer declines any responsibility in case of installation which are not in compliance with current regulations, in case of a wrong room ventilation system, in case of an electric connection which is not in compliance with regulations and in case of a wrong use of the appliance.
- It is forbidden to install the stove in bedrooms, bathrooms and in rooms used for storing combustible materials and in one-room flats.
- The installation in one-room flats is allowed if they are in sealed chamber.
- In any case the stove must not be installed in rooms where it can get in touch with water or water splashes because this can cause burn hazards and short-circuit.
- Please check that the floor has an adequate load capacity. If the existing one does not satisfy this requirement, appropriate measure should be provided (for example a plate for distributing the load).
- For safety fire regulations the distances from flammable or sensible to heat objects (sofas, pieces of furniture, wooden covering, etc...) must be respected.
- If there are highly flammable objects (curtains, fitted carpet, etc...), all these distances must be further increased with 1 meter.
- If the floor is made of combustible material, we recommend using a protector made of incombustible material (steel, glass, etc.) that also protects the front part from any falling burnt particles during cleaning.
- The electrical cable must not get in touch with the fume exhaust pipe and nor with every other part of the stove.
- The user, or whoever is operating the product, must read and fully understand the contents of this installation and use guide before performing any operation. Errors or incorrect settings can cause hazardous conditions and/or poor operation.
- The type of fuel to use is only the pellets.
- Do not use the appliance as waste incinerator.
- Do not place laundry on the product to dry. Any clothes horses or similar objects must be kept at a safe distance from the product. Fire hazard.
- It is forbidden to operate the product with the door open or the glass broken.
- It is forbidden to modify the appliance without authorization.
- Do not use flammable liquids during the ignition (alcohol, petrol, oil, etc...).
- After a failed ignition the burning pot must be empty from the amassed pellets, before starting the stove up again.
- The pellet hopper must always be closed with its own lid.
- Before of every intervention leave the fire completely extinguish till the cooling and always disconnect the plug from the electric socket.
- This appliance can be used by children aged from 8 years and above and persons with reduced physical, sensory or mental capabilities or lack of experience and knowledge if they have been given supervision or instruction concerning use of the appliance in a safe way and understand the hazards involved. Children shall not play with the appliance. Cleaning and user maintenance shall not be made by children without supervision.
- Packaging are not toys and could cause suffocation or strangulation and other health hazards! People (children included) with reduced mobility, psychological diseases or without

experience and knowledge must be kept away from packaging. The stove is not a toy.

- Children must be constantly overseen in order to assure that they do not play with the appliance.
- During its running, the stove reaches high temperatures: keep away children and animals and for your safety please use appropriate fireproof devices, such as heat-protecting gloves.
- The stove is equipped with a safety device that stops the feed screw immediately when the pellet loading door is opened. This safety device (standard EN 60335-2-102) prevents the user from coming into contact with the moving parts of the appliance.
- The chimney flue must be cleaned, since the soot and unburnt oil deposits reduce its section so blocking the draught. In great quantities they can flare up.
- If the pellets are of bad quality (if contains sizing agents, oils, varnishes, plastic remains or if it is mealy), deposits will form along pellets drop pipe during the running. When the stove is switched off, these remains could form little hot coals that rising along the pipe could reach the pellets on the hopper burning them and creating a thick and harmful smoke inside the room. Please always keep the hopper closed with its own lid. If the pipe is sooty, please clean it.
- In case it would be necessary to extinguish the fire emitted by the stove or by the chimney flue, use a fire-extinguisher or contact the firemen. **Do not** use water to extinguish the fire inside the burning pot.

5 WARRANTY CONDITIONS

The company guarantees the product, **with the exception of elements subject to normal wear** listed below, for a period of **2 (two) years** from the date of purchase attested by:

- a document to serve as proof of purchase (invoice and/or receipt) that shows the name of the vendor and the date on which the purchase was made;
- forwarding of the completed certificate of guarantee within 8 days of purchase.

Furthermore, the product must be installed and started by specialised personnel who must, where provided, issue a declaration of conformity of the plant and of the proper functioning of the product, for the warranty to be valid and effective.

We recommend testing the product before completion with the relative finishes (claddings, painting of walls, etc.).

Installations not meeting the current standards, improper use and lack of maintenance as expected by the manufacturer, void the product warranty.

The guarantee is valid on the condition that the instructions and warnings contained in the use and maintenance manual are observed, and therefore the product is used correctly.

The replacement of the entire system or the repair of one of its components does not extend the guarantee period, and the original expiry date remains unchanged.

The guarantee covers the replacement or free repair **of parts recognised as being faulty at source due to manufacturing defects**.

To benefit from the guarantee, in the event of a fault, the customer must have the guarantee certificate and present it with the proof of purchase document to the Technical Assistance Office.

The guarantee does not cover malfunctions and/or damage to the appliance that arise due to the following causes:

- Damage caused during transportation or relocation.
- All parts that develop faults due to negligence or improper use, incorrect maintenance, installation that does not comply with the manufacturer's instructions (always refer to the installation and use manual provided with the appliance).
- Incorrect dimensioning with regards to the use or faults in the installation or failure to adopt the necessary devices to guarantee proper execution.
- Improper overheating of the equipment, use of fuels not conforming to the types and quantities indicated in the instructions provided.
- Further damage caused by incorrect user interventions in an attempt to fix the initial fault.
- Worsening of the damage due to the continued use of the equipment by the user, once the defect has been noticed.
- In the presence of a boiler, any corrosions, incrustations or breaks caused by water flow, condensation, hardness or acidity of the water, improperly performed descaling treatments, lack of water, mud or limescale deposits.
- Inefficiency of chimneys, flues or parts of the plant affecting the equipment.
- Damage caused by tampering with the appliance, atmospheric agents, natural disasters, vandalism, electrical discharges, fires,

- faults in the electric and/or hydraulic system.
- Failure to have the stove cleaned on an annual basis by an authorised technician or qualified personnel will result in the loss of the warranty.

Also excluded from this guarantee are:

- Parts subject to normal wear such as gaskets, glass, claddings and cast iron grids, painted, chrome-plated or gilded parts, handles and electric cables, bulbs, indicator lights, knobs, all parts which can be removed from the hearth.
- Variations in colour of the painted or ceramic/serpentine parts and craquelure ceramics as they are natural characteristics of the material and product use.
- Masonry work.
- Plant parts (if present) not supplied by the manufacturer.

Any technical interventions on the product to eliminate the above-said defects and consequent damages must be agreed upon with the Technical Assistance Centre, who reserves the right to accept the relative appointment or not. However, said interventions will not be carried out under warranty but as technical assistance to be granted at part of any eventual and specific agreed conditions and in accordance with the fee in force for the work to be carried out.

The user will also be charged for any costs incurred to remedy the incorrect technical interventions, tampering or damage to the appliance, not attributable to original faults.

Save for the legal or regulatory limits, the guarantee does not cover the containment of atmospheric and acoustic pollution.

The company declines all liability for any damage which may be caused, directly or indirectly, to persons, animals or objects as a consequence of non compliance with any prescription specified in the manual, especially warnings regarding installation, use and maintenance of the appliance.

6 SPARE PARTS

For each repair or adjustment which should be necessary, please contact the dealer where you purchased your stove or your nearest Technical Assistance Service, specifying:

- Appliance model
- Serial number
- Type of problem

Use only original spare parts which you can find at our Technical Assistance Services.

7 WARNINGS FOR THE CORRECT DISPOSAL OF THE PRODUCT

The owner is the sole party responsible for demolishing and disposing of the product. This must be performed in compliance with laws related to safety and environmental protection in force in his/her country.

At the end of its working life, the product must not be disposed of as urban waste.

It must be taken to a special differentiated waste collection centre set up by the local authorities or to a retailer that provides this service.

Separating and recycling prevents potential negative effects on the environment and health (often caused by inappropriately disposing of product parts). It also allows materials to be recovered in order to obtain significant savings in energy and resources.

7.1 INFORMATION FOR MANAGEMENT OF ELECTRIC AND ELECTRONIC APPLIANCE WASTE CON-

TAINING BATTERIES OR ACCUMULATORS

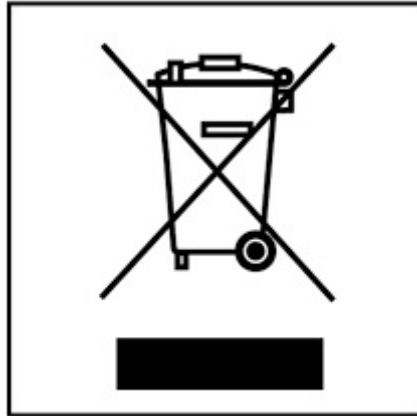

Fig. 1 - Waste disposal

This symbol, which is used on the product, batteries, accumulators or on the packaging or documents, means that at the end of its useful life, this product, the batteries and the accumulators included must not be collected, recycled or disposed of together with domestic waste.

Improper management of electric or electronic waste or batteries or accumulators can lead to the leakage of hazardous substances contained in the product. For the purpose of preventing damage to health or the environment, users are kindly asked to separate this equipment and/or batteries or accumulators included from other types of waste and to arrange for disposal by the municipal waste service. It is possible to ask your local dealer to collect the waste electric or electronic appliance under the conditions and following the methods provided by national laws transposing the Directive 2012/19/EU.

Separate waste collection and recycling of unused electric and electronic equipment, batteries and accumulators helps to save natural resources and to guarantee that this waste is processed in a manner that is safe for health and the environment.

For more information about how to collect electric and electronic equipment and appliances, batteries and accumulators, please contact your local Council or Public Authority competent to issue the relevant permits.

8 WI-FI CONNECTION - BLUETOOTH

8.1 NAVEL STAND ALONE



Procedure if only valid for models with NAVEL STAND ALONE Wi-Fi technology.



ATTENTION! Installation must **ONLY** be carried out by specialised personnel.

The manufacturer will not be held responsible for injury to persons or damage to property or in the event of failed operation.

The Wi-Fi module uses the domestic Wi-Fi network; ensure there is enough coverage in the place of installation.

Categories	Items	Specifications
Wi-Fi	Protocols	802.11 b/g/n (802.11n up to 150 Mbps) A-MPDU and A-MSDU aggregation and 0.4 μ s guard interval support
	Frequency range	2412 ~ 2484 MHz
Bluetooth	Protocols	Bluetooth v4.2 BR/EDR and BLE specification
	Radio	NZIF receiver with -97 dBm sensitivity
		Class-1, class-2 and class-3 transmitter
Audio	AFH CVSD and SBC	





Fig. 2 - NAVEL STAND ALONE module



Fig. 3 - App EASY CONNECT PLUS

The documentation for connecting the Wi-Fi and using the App are available online at the following addresses:

	https://www.cadelsrl.com/download-wi-fi/
	http://www.free-point.it/it/downloads/
	https://www.pegasoheating.com/it/documenti/

9 USE

9.1 INTRODUCTION

To have the best performance with the lowest consumption please follow the here described instructions.

- The lightning of the pellets occurs very easily if the installation is correct and if the chimney flue is efficient.
- Switch on the stove at Power 1 for at least 2 hours in order to enable the materials which make up the boiler and the fireplace to adjust the inner springing stress.

- By using the stove the varnish inside the combustion chamber could be subjected to alterations. This occurrence can be attributed to different reasons: an excessive stove overheating, the presence of chemical agents in bad quality pellets, bad chimney draught, etc. Therefore varnish endurance in the combustion chamber cannot be guaranteed.



Oily plant waste and lacquers can cause smells and smoke during the first working hours: it is advisable to ventilate the room because they could be noxious to people and animals.



Set values from 1 to 5 are defined by the manufacturer and they can be changed only by an authorized technician.

9.2 CONTROL PANEL

The display allows you to dialogue with the stove by simply pressing a few buttons. A display with scrolling text and LED indicators inform the user about the stove's operating status.

Meaning of the buttons (see Fig. 2)

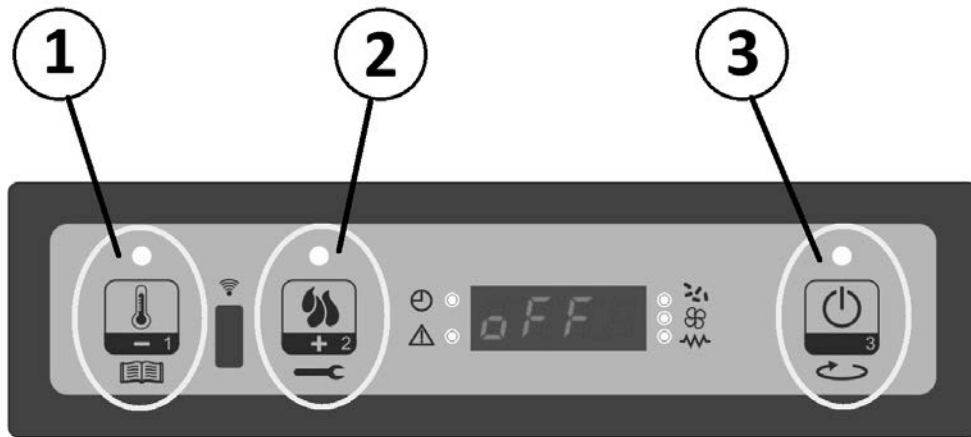



Fig. 4 - Display: 3 buttons

REFERENCE	BUTTON	DESCRIPTION	MODE	ACTION
1		Decreases temperature and power	TEMPERATURE SETTING	Decreases the value of the ambient temperature SETTING
			PROGRAMMING	Decreases the selected parameter
			POWER SETTING	Decreases the value of the operating power
2		Increases the temperature and power	TEMPERATURE SETTING	Increases the value of the ambient temperature SETTING
			PROGRAMMING	Increases the selected parameter
			POWER SETTING	Increases the value of the operating power

REFERENCE	BUTTON	DESCRIPTION	MODE	ACTION
3		ON/OFF	WORK	Pressed for 2 seconds, it turns the stove on or off accordingly
			PROGRAMMING	Allows you to select the parameters to be programmed

Meaning of the LEDs that are on (see Fig. 3):

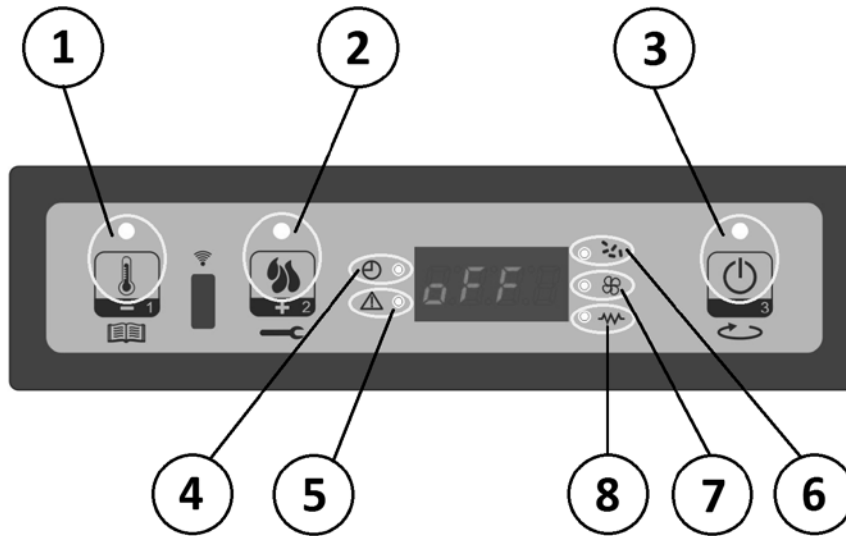









Fig. 5 - Display: LEDs on

REFERENCE	SYMBOL	DESCRIPTION	LED ON
1		AMBIENT SETTING	Ambient setting programming
2		POWER SETTING	Power setting programming
3		ON/OFF	Work status
4		CHRONO	Chrono is enabled
5		ALARM	Stove is in alarm

REFERENCE	SYMBOL	DESCRIPTION	LED ON
6		FEED SCREW ON	Feed screw moving
7		HEAT EXCHANGER	Heat exchanger on
8		SPARK PLUG	Ignition spark plug

9.3 USER MENU

The following table briefly describes the menu structure; this paragraph solely focuses on the selections available to the user.

LEVEL 1	LEVEL 2	LEVEL 3	VALUE
M1 Set orologio <i>M1-SEt cLock</i>			
	01 - Day of the week		M-T-W-T-F-S-S <i>Mond-tuES-uEdn-tHur-Frid- SAtu-Sund</i>
	02 - Clock hours <i>02-tiME cLock</i>		0-23
	03 - Clock minutes <i>03-MinutES cLock</i>		0-59
	04 - Clock day <i>04-dAy cLock</i>		1-31
	05 - Clock month <i>05-Month cLock</i>		1-12
	06 - Clock year <i>06-yEAR cLock</i>		00-99
M2 - Chrono setting <i>M2-SEt cHrono</i>			
	M2-1 - Enable chrono <i>M2-1 cHrono EnABLE</i>		
		01 - enable chrono <i>01-cHrono EnABLE</i>	on/off
	M2-2 - Daily programming <i>M2-2 ProGrAM dAy</i>		
		01 - daily chrono <i>01-cHrono dAyLy</i>	on/oFF
		02 - start 1 day <i>02-StArt 1 dAyLy</i>	oFF-0-23:50

LEVEL 1	LEVEL 2	LEVEL 3	VALUE
		03 - stop 1 day <i>03-StoP 1 dAyLy</i>	<i>oFF-0-23:50</i>
		04 - start 2 day <i>04-StArt 2 dAyLy</i>	<i>oFF-0-23:50</i>
		05 - stop 2 day <i>05-StoP 2 dAyLy</i>	<i>oFF-0-23:50</i>
	M2-3 - Weekly programming <i>M2-3 -ProGrAM uEEK</i>		
		01 - week chrono <i>01-crono uEEKLy</i>	<i>on/oFF</i>
		02 - start Prg 1 <i>02-StArt PrG1</i>	<i>oFF-0-23:50</i>
		03 - stop Prg 1 <i>03-StoP PrG1</i>	<i>oFF-0-23:50</i>
		04 - Monday Prg1 <i>04-Mond PrG1</i>	<i>on/oFF</i>
		05 - Tuesday Prg 1 <i>05-tuES PrG1</i>	<i>on/oFF</i>
		06 - Wednesday Prg 1 <i>06-uEdn PrG1</i>	<i>on/oFF</i>
		07 - Thursday Prg1 <i>07-tHur PrG1</i>	<i>on/oFF</i>
		08 - Friday Prg 1 <i>08-Frid PrG1</i>	<i>on/oFF</i>
		09 - Saturday Prg 1 <i>09-SAtu PrG1</i>	<i>on/oFF</i>
		10 - Sunday Prg 1 <i>10-Sund PrG1</i>	<i>on/oFF</i>
		11 - start Prg 2 <i>11-StArt PrG2</i>	<i>oFF-0-23:50</i>
		12 - stop Prg 2 <i>12-StoP PrG2</i>	<i>oFF-0-23:50</i>
		13 - Monday Prg2 <i>13-Mond PrG2</i>	<i>on/oFF</i>
		14 - Tuesday Prg 2 <i>14-tuES PrG2</i>	<i>on/oFF</i>
		15 - Wednesday Prg 2 <i>15-uEdn PrG2</i>	<i>on/oFF</i>
		16 - Thursday Prg2 <i>16-tHur PrG2</i>	<i>on/oFF</i>
		17 - Friday Prg 2 <i>17-Frid PrG2</i>	<i>on/oFF</i>

LEVEL 1	LEVEL 2	LEVEL 3	VALUE
		18 - Saturday PrG 2 <i>18-SAtu PrG2</i>	<i>on/oFF</i>
		19 - Sunday PrG 2 <i>19-Sund PrG2</i>	<i>on/oFF</i>
		20 - start PrG 3 <i>20-StArt PrG3</i>	<i>oFF-0-23:50</i>
		21 - stop PrG 3 <i>21-StoP PrG3</i>	<i>oFF-0-23:50</i>
		22 - Monday PrG3 <i>22-Mond PrG3</i>	<i>on/oFF</i>
		23 - Tuesday PrG 3 <i>23-tuES PrG3</i>	<i>on/oFF</i>
		24 - Wednesday PrG 3 <i>24-uEdn PrG3</i>	<i>on/oFF</i>
		25 - Thursday PrG3 <i>25-tHur PrG3</i>	<i>on/oFF</i>
		26 - Friday PrG 3 <i>26-Frid PrG3</i>	<i>on/oFF</i>
		27 - Saturday PrG 3 <i>27-SAtu PrG3</i>	<i>on/oFF</i>
		28 - Sunday PrG 3 <i>28-Sund PrG3</i>	<i>on/oFF</i>
		29 - start PrG 4 <i>29-StArt PrG4</i>	<i>oFF-0-23:50</i>
		30 - stop PrG 4 <i>30-StoP PrG4</i>	<i>oFF-0-23:50</i>
		31 - Monday PrG4 <i>31-Mond PrG4</i>	<i>on/oFF</i>
		32 - Tuesday PrG 4 <i>32-tuES PrG4</i>	<i>on/oFF</i>
		33 - Wednesday PrG 4 <i>33-uEdn PrG4</i>	<i>on/oFF</i>
		34 - Thursday PrG4 <i>34-tHur PrG4</i>	<i>on/oFF</i>
		35 - Friday PrG 4 <i>35-Frid PrG4</i>	<i>on/oFF</i>
		36 - Saturday PrG 4 <i>36-SAtu PrG4</i>	<i>on/oFF</i>
		37 - Sunday PrG 4 <i>37-Sund PrG4</i>	<i>on/oFF</i>
	M2-4 - Weekend program <i>M2-4-ProGrAM u-End</i>		

LEVEL 1	LEVEL 2	LEVEL 3	VALUE
		01 - weekend chrono <i>01-chrono uEEK End</i>	<i>on/oFF</i>
		02 - start weekend 1 <i>02-StArt 1 uEEK End</i>	<i>oFF-0-23:50</i>
		03 - stop weekend 1 <i>03-StoP 1 uEEK End</i>	<i>oFF-0-23:50</i>
		04 - start weekend 2 <i>04-StArt 2 uEEK End</i>	<i>oFF-0-23:50</i>
		05 - stop weekend 2 <i>05-StoP 2 uEEK End</i>	<i>oFF-0-23:50</i>
	M2-5 - Exit <i>M2-5-ESCAPE</i>		set
M3 - Choose language <i>M3-LAnGuAGE</i>			
	01 - Italian <i>01-LinG itA</i>		set
	02 - English <i>02-LinG EnG</i>		set
	03 - French <i>03-LinG FrE</i>		set
	04 - German <i>04-LinG dEu</i>		set
	05 - Spanish <i>05-LinG SPA</i>		set
	06 - Portuguese <i>06-LinG Por</i>		set
M4 - Stand-by <i>M4-StAnd-by</i>			
	01 - Stand - by <i>01-StAnd-by</i>		<i>on/oFF</i>
M5 - Buzzer <i>M5 buCCEr</i>			
	01 - Buzzer <i>01-buCCEr</i>		<i>on/oFF</i>
M6 - First load <i>M6 LoAd initiAL</i>			
	01 - First load <i>01-LoAd initiAL</i>		90"
M7 - Stove status <i>M7 StAtE StoVE</i>			
	01 - Stove status <i>01-StAtE StoVE</i>		

LEVEL 1	LEVEL 2	LEVEL 3	VALUE
		01 - Feed screw status	info
		02 - T minutes	info
		03 - Thermostat status	info
		04 - Flue gas status	info
		05 - Flue gas extraction rpm status	info
M8 - Engineer settings <i>M8 SEt tEcHnic</i>			
	01 - Password <i>01-KEy AccESS</i>		set
M9 - Pellet type <i>M9 tyPE PELLEt</i>			
	01 - Loading pellets <i>01-Pr 54 LoAd PELLEt</i>		da -9 a +9
MA - Flue type <i>MA tyPE cHiMnEy</i>			
	01 - Flue extractor <i>01-Pr 55 SMoKE cHiMnEy</i>		da -9 a +9
MB - Exit <i>Mb ESCAPE</i>			
	01 - Exit <i>01-ESCAPE</i>		set

9.3.1 Menu M1 - CLOCK SETTING

Set the current time and date. The board has a lithium battery that assures the internal clock life of more than 3-5 years. Press the P1 button for 2 seconds to access the general programming menus. Pressing P1 (decreases) or P2 (increases) selects item M1, and **M1 SET cLock** will scroll "M1-SEt cLock" (see Fig. 4).



Fig. 6 - Display: M1

9.3.2 Menu M2 - CHRONO SETTING

Submenu M2-1 Enable chrono

The menu shown on the **M2 chrono setting** "cHrono EnABLE" display allows you to globally enable and disable all the chrono-thermostat functions. Enable by pressing button P3 and then pressing P1 or P2 for the On or Off section. Confirm with the P3 button (see Fig. 5).



Fig. 7 - Display: enables

Submenu M2 - 2 - Day program

After selecting the **M2 - 2 day program** "ProGrAM dAy" menu, using the P3 button you will scroll through the various daily chrono programming parameters, including enabling it (see Fig. 6).



Fig. 8 - Display: crono

Two operating ranges can be set, the first with **START1 Day** "StArt 1 dAyLy" and **STOP1 Day** "StoP 1 dAyLy", the second with **START2 Day** "StArt 2 dAyLy" and **STOP2 Day** "StoP 2 dAyLy", delimited by the times set according to the table below where the OFF setting indicates the clock to ignore the command. Use buttons P1 (decreases) and P2 (increases) to vary, and P3 to confirm.

DAY PROGRAM			
MENU LEVEL	SELECTION	MEANING	POSSIBLE VALUES
M2-2-01	cHrono dAyLy	Enables the daily chrono	ON/OFF
M2-2-02	StArt 1 dAyLy	activation time	OFF-0-23:50
M2-2-03	StoP 1 dAyLy	deactivation time	OFF-0-23:50
M2-2-04	StArt 2 dAyLy	activation time	OFF-0-23:50
M2-2-05	StoP 2 dAyLy	deactivation time	OFF-0-23:50

Submenu M2 - 3 - weekly program

The **M2-3 Weekly Program** "ProGrAM uEEK" menu allows you to enable/disable and set the weekly chronothermostat functions. The weekly function has 4 independent programs. Furthermore, by setting OFF in the time field, the clock ignores the corresponding command.

The tables below summarise the weekly program function. Press the P3 button to access the next function and confirm the value. It is possible to exit the menu by pressing the P3 button for long.

ENABLING WEEKLY CHRONO			
MENU LEVEL	SELECTION	MEANING	POSSIBLE VALUES
M2-3-01	crono uEEKLy	Enables the weekly chrono	ON/OFF

PROGRAM 1			
MENU LEVEL	SELECTION	MEANING	POSSIBLE VALUES
M2-3-02	StArt PrG1	activation time	OFF-0-23:50
M2-3-03	StoP PrG1	deactivation time	OFF-0-23:50

PROGRAM 1			
M2-3-04	Mond PrG1	reference day	on/off
M2-3-05	tuES PrG1		on/off
M2-3-06	uEdn PrG1		on/off
M2-3-07	tHur PrG1		on/off
M2-3-08	Frid PrG1		on/off
M2-3-09	SAtu PrG1		on/off
M2-3-10	Sund PrG1		on/off

PROGRAM 2			
<i>MENU LEVEL</i>	<i>SELECTION</i>	<i>MEANING</i>	<i>POSSIBLE VALUES</i>
M2-3-11	StArt PrG2	activation time	off-0-23:50
M2-3-12	StoP PrG2	deactivation time	off-0-23:50
M2-3-13	Mond PrG2	reference day	on/off
M2-3-14	tuES PrG2		on/off
M2-3-15	uEdn PrG2		on/off
M2-3-16	tHur PrG2		on/off
M2-3-17	Frid PrG2		on/off
M2-3-18	SAtu PrG2		on/off
M2-3-19	Sund PrG2		on/off

PROGRAM 3			
<i>MENU LEVEL</i>	<i>SELECTION</i>	<i>MEANING</i>	<i>POSSIBLE VALUES</i>
M2-3-20	StArt PrG3	activation time	off-0-23:50
M2-3-21	StoP PrG3	deactivation time	off-0-23:50
M2-3-22	Mond PrG3	reference day	on/off
M2-3-23	tuES PrG3		on/off
M2-3-24	uEdn PrG3		on/off
M2-3-25	tHur PrG3		on/off
M2-3-26	Frid PrG3		on/off
M2-3-27	SAtu PrG3		on/off
M2-3-28	Sund PrG3		on/off

PROGRAM 4			
<i>MENU LEVEL</i>	<i>SELECTION</i>	<i>MEANING</i>	<i>POSSIBLE VALUES</i>
M2-3-29	StArt PrG4	activation time	off-0-23:50
M2-3-30	StoP PrG4	deactivation time	off-0-23:50

PROGRAM 4			
M2-3-31	Mond PrG4	reference day	on/off
M2-3-32	tuES PrG4		on/off
M2-3-33	uEdn PrG4		on/off
M2-3-34	tHur PrG4		on/off
M2-3-35	Frid PrG4		on/off
M2-3-36	SAtu PrG4		on/off
M2-3-37	Sund PrG4		on/off

Submenu M2 - 4 - weekend program

Allows you to enable/disable and set the weekend chronothermostat functions (day 6 and 7, i.e. Saturday and Sunday). Enable by pressing the P3 button in **01 - the weekend chrono** "cHrono uEEK End" setting and set "on" using the P1 (decreases) or P2 (increases) button. Setting the [CS:Grassetto:02 - Start 1 weekend[2:]] "StArt 1 uEEK End" and **03 - Stop1 weekend times** "StoP 1 uEEK End" sets the operating period for **Saturday**, "SAtu" whereas **04 - Start 2 weekend** "StArt 2 uEEK End" and **05 - Stop 2 weekend** "StoP 2 uEEK End" sets the stove operation for **Sunday** "Sund".

WEEK-END PROGRAM			
MENU LEVEL	SELECTION	MEANING	POSSIBLE VALUES
M2-4-01	cHrono uEEK End	Enables the weekend chrono	on/off
M2-4-02	StArt 1 uEEK End	activation time	off-0-23:50
M2-4-03	StoP 1 uEEK End	deactivation time	off-0-23:50
M2-4-04	StArt 2 uEEK End	activation time	off-0-23:50
M2-4-05	StoP 2 uEEK End	deactivation time	off-0-23:50

9.3.3 Menu M3 - LANGUAGE SELECTION

Allows you to select the dialogue language from those available (see vedi **Fig. 7**). To switch to the next language press P2 (increases), to go backwards press P1 (decreases), and to confirm press P3.



Fig. 9 - Display: language

9.3.4 Menu M4 - STAND-BY

Allows you to enable or disable the [CS:Grassetto:M4 - Stand-by[2:]] "M4 StAnd-by" mode (see **Fig. 8**). Once the M4 menu has been selected with the P3 button, press P1 (decreases) or P2 (increases) to change the state from ON to OFF and viceversa.



Fig. 10 - Display: stand-by

9.3.5 Menu M5 - BUZZER

Allows you to enable or disable the buzzer of the controller when alarms are indicated (see Fig. 9). Enable or disable with buttons P1 or P2, and confirm with P3.



Fig. 11 - Display: buzzer

9.3.6 Menu M6 - FIRST LOAD

This function is only available when the stove is OFF and allows the feed screw to be loaded with the first start-up of the stove, when the pellet tank is empty. After selecting menu M6, the message **Press More "PrESS MorE"** will scroll on the display (see Fig. 10). Then press P2 (increases). The flue gas fan turns on at maximum speed, the feed screw turns on (feed screw LED on) and they remain until the time indicated on the display elapses (see Fig. 11), or until button P3 is pressed.



Fig. 12 - Display: press more



Fig. 13 - Display: time left

9.3.7 Menu M7 - STOVE STATUS

Once in menu M7, after pressing button P3, the status of some variables scrolls on the display while the stove is working. The table below shows an example of the display and its meaning of these values.

STATUS DISPLAYED	MEANING
3,1"	Pellet loading feed screw status
52'	Time out
Toff	Thermostat status
106°	Flue Gas Temperature
1490	Flue gas extraction speed

9.3.8 Menu M8 - ENGINEER SETTINGS

This menu item is reserved for the stove installer. After entering the password (see Fig. 12) it allows you to set the various operating parameters of the stove using buttons P1 (decreases) and P2 (increases).



Fig. 14 - Display: key

9.3.9 Menu M9 - PELLET TYPE

It allows you to adjust the quality of combustion and the flame based on the fuel quality or draft of the flue (see Fig. 13). Thanks to this adjustment the fuel supply in the burn pot may be modified by an amount between -18% and +18% (value from -9 = -18% to +9 = +18%).



Fig. 15 - Display: pellet type

9.3.10 Menu MA - FLUE TYPE

The RPM of the flue gas extractor fan may be changed as a percentage to counter some draft issues or reduce extraction in case of flues with excess draft (see Fig. 14).

The flue gas extractor speed adjustment can vary between -18% and +18% (value from -9 = -18% to +9 = +18%).



Fig. 16 - Display: ue type

9.3.11 Menu MB - EXIT

Selecting this item by pressing button P3 (see Fig. 15), exits the menu and returns to the previous state.



Fig. 17 - Display: exit

9.4 STOVE SWITCH-ON

We remind you that the first start-up must be carried out by skilled and authorised technical personnel who check that everything is installed according to the regulations in force and verifies its functionality.

- If inside the combustion chamber there are booklets, manuals, etc. remove them.
- Check that the door is closed properly.
- Check that the plug is inserted into the socket.

- Before turning the stove on, make sure that the burn pot is clean.

Start up the stove by pressing button P3 for a few seconds so that **Turn on "StArt"** is displayed. In these conditions, the stove goes into the preheating state: the spark plugs go on (visible from the spark plug LED) together with the flue gas extraction fan. Any anomalies during the ignition phase are shown on the display and the stove goes into alarm status.

The pellet loading phase starts after about 1 minute, and the display shows the message **Pellet loading "LoAd PELLEt"** and the ON/OFF LED flashes intermittently. In the first phase, the feed screw loads the pellet into the burn pot. After the temperature of the flue gas has reached and exceeded the contained value, the system goes into ignition mode and **Fire present "FLAME LiGHt"** appears on the display and the ON/OFF LED flashes.

When the flue gas temperature has reached and exceeded the intended value, the stove goes into the normal operating mode. The display shows the word **Work "uork"** and the ON/OFF LED is lit.

The power can be set by keeping button P2 pressed and the room temperature can be set by pressing button P1.

At set intervals, an automatic burn pot cleaning is performed in order to prevent dash from accumulating. On the display you will see **Cleaning fire-pot "cLEANinG FirE-Pot"**.

If this function lasts for a few seconds, it is NOT an alarm.



Fig. 18 - Display

9.5 FAILED IGNITION

If the pellets do not burn, the failed ignition will be indicated by the alarm **AL 5 FAILED IGNITION "AL 5 ALAr no LiGHtin"**.

If the room temperature is lower than 10°C, the plug is not able to bear the ignition stage. To support it please insert some pellets in the burning pot and a piece of burning firelighter igniter material on the pellets (for example firelighters cubes).

Too much pellets in the burning pot, or humid pellet, or sooty burning pot make ignition difficult and create dense white smoke which is harmful to health and can cause explosions on the combustion chamber. It is therefore necessary not to stand in front of the stove during ignition stage if dense white smoke is present.



If after some months the flame appears weak and/or orange colored or the glass tends to blackens and the burning pot to become encrusted, clean the stove, clean the fume conduit and the chimney flue.

9.6 POWER FAILURE

After a **Black-out "bLAc-out"** lower than 5 seconds, the stove turns back to the power which was settled.

After a **Black-out "bLAc-out"** of more than 5 seconds, the stove enters the **COOLING WAIT "uAit coolinG"** phase. Completed this phase, it starts automatically up with the different phases (see **STOVE SWITCH-ON a pag. 20**).

9.7 TEMPERATURE SETTING

Change the room temperature by simply pressing button P1.

The display shows the set room temperature (temperature SETTING).

Therefore, the value can be changed by pressing buttons P1 (decreases) and P2 (increases).

After about 5 seconds the value is saved and the display returns to normal display, or exit by pressing P3.

9.8 POWER SETTING

Change the set power by simply pressing button P2. The display shows the set power (power SETTING). Therefore, the value can be changed by pressing buttons P1 (decreases) and P2 (increases).

After about 5 seconds the value is saved and the display returns to normal display, or exit by pressing P3.

NOTE: when the room temperature has reached the set value, the heating power of the stove is automatically brought to the mi-

nimum value. In these conditions, the display shows the message **Modulate** " *ModuLAt* ".

If the room temperature drops below the set temperature, the stove returns to "**Work**" " *uork* " mode at the previously set power.

9.9 SWITCHING OFF

Switch the stove off by simply pressing and holding down button P3. Pul-Finale "*cLEAninG SPEEd*" appears on the display. After a certain time, the stove switches off, and **Off** " *oFF* " is displayed.

9.10 CONNECTION TO THE EXTERNAL THERMOSTAT

The stove works through a thermostat probe placed in its inner. If you desire, the stove can be connected to an external room thermostat. This operation must be executed by an authorized technician.

10 FUEL

10.1 FUEL

- Use top-quality pellets because they have influence in the calorific value and in ash remains.
- Pellets features are: dimension Ø6-7mm (D06 Class), maximum lenght 40 mm, calorific value 5kWh/kg, humidity 10%, ash remains 0,7%, they must be correctly pressed and not much mealy, without sizing agents, resins and other additives (class A1 pellets according to ISO 17225-2 (type ENplus-A1) are recommended).
- Not adequate pellets cause a bad combustion, a frequent burning pot obstruction and exhaust conduits obstruction. Further it decreases the calorific value, soils the glass and increases consumptions and ash and unburnt granules quantity.



Humid pellets cause a bad combustion and running, so please assure you that they are stored in dry places and far at least one meter from the stove and/or any other source of heat.

- It is advisable to try different type of pellets available on the market and to choose that which gives the best performance.
- The use of bad quality pellets can damage the stove so that the warranty and manufacturer liability fall.
- Pellets of variable quality and size are available on the market: the smaller the pellet, the greater the fuel supply, resulting in poor combustion



Depending on the type of pellets it could be necessary a parameters adjustment, please contact an Authorized Assistance Service.

10.2 PELLET SUPPLY



Fig. 19 - Wrong opening of the pellets bag



Fig. 20 - Right opening of the pellets bag

It is necessary to avoid to fill the hopper with the pellet when the stove is running.

- Do not get the bag of pellet in contact with hot stove surfaces.
- Do not empty the hopper with remaining fuels (unburnt pellet) from the burning pot coming from ignition waster.

10.3 PELLET REFUELLING TIMER

This stove is equipped with a safety timer that activates after the pellet hopper door has been open for **90 seconds** during reloading (see Fig. 19 and Fig. 20). After 90 seconds, the stove goes into "A05" depression alarm and proceeds to switch off. Wait until it switches off, then light it again.



Fig. 21 - Door open

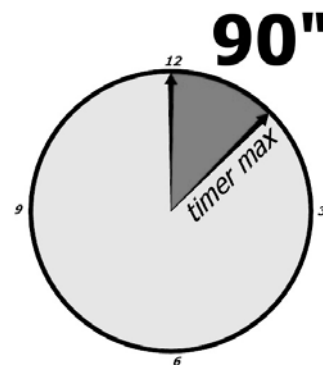

Fig. 22 - Timer: 90 seconds



To operate correctly, the stove must work with the pellet hopper door always closed; should it remain open for more than 90 seconds, the stove switches off.

- The loading system stops when the tank door is opened.

10.4 VENTILATION

- The stove is endowed with a ventilation system.
- The air blown from fans keeps the appliance at a low temperature range in order to avoid high stresses to the materials which make it up.
- Do not cover the hot air outlet slits with any object to avoid stove's overheating!
- The stove is not suitable for food cooking.



Fig. 23 - Do not cover air slits

10.5 REMOTE CONTROL (OPTIONAL)

- The stove can be operated through a remote control (optional)
- Operation requires 1 CR 2025 (3Volt) Lithium battery
- Operating temperature 0 °C / 50 °C
- 38 khz infrared signal

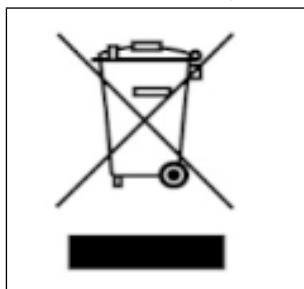

Used batteries contain metals which are harmful for the environment; they must therefore be disposed of separately in the special containers.



Fig. 24 - Remote control

LEGEND	Fig. 22
Button 1	Increase the desired temperature
Button 2	Decrease the desired temperature
Button 3	On / off
Button 4	Menu
Button 5	Decrease the power level from 5 to 1
Button 6	Increase the power level from 1 to 5

11 SAFETY DEVICES AND ALARMS

11.1 SAFETY DEVICES

The product is supplied with the following safety devices

11.2 PRESSURE SWITCH

- It controls pressure in the fume duct. It blocks the pellet feed screw in the following instances:
 - - clogged exhaust
 - - Significant negative (wind)
 - - clogged fume passages
 - - open pellet loading tank
 - - open fire door or worn/broken gaskets.

11.3 SMOKE TEMPERATURE PROBE

Detects the temperature of the smoke, thereby enabling start-up or stopping the product when the temperature drops below the preset value.

11.4 CONTACT THERMOSTAT IN THE FUEL HOPPER

If the temperature exceeds the preset safety level, it immediately shuts down boiler operation.

11.5 ELECTRICAL SAFETY

The product is protected against sudden current surges by a main fuse in the power supply panel on the rear part of the product. Other fuses that protect the electronic boards are found on the latter.

11.6 SMOKE FAN

If the fan stops, the electronic board promptly shuts off the pellets supply and an alarm message is displayed.

11.7 GEAR MOTOR

If the gear motor stops, the boiler will continue to run until the flame goes out due to lack of fuel and until a minimum level of cooling is reached.

11.8 TEMPORARY POWER CUT

If the power cut lasts less than 10" the boiler returns to its previous operating status; if it lasts more it carries out a cooling/restart cycle.

11.9 FAILED START-UP

If during ignition no flame develops, the boiler will go into alarm condition.

11.10 BLACKOUT WITH THE BOILER ON

In the event of a power cut **BLACK-OUT "blAc-out"** the boiler behaves as follows:

- Blackout below 5": it returns to its operation in progress;
- In the event of a power cut that lasts over 5" with the boiler on or in the start-up stage, when the boiler is powered again it goes back to the previous operating condition with the following procedure:
 - 1) It performs a cooling phase to the maximum.
 - 2) Performs a new ignition.

The display will show the message **Al 1 alar al 1 Blac-out** "AL 1 bLAc-out" (see Fig. 23) and the stove will shut down.



Fig. 25 - Display: AL 1

11.11 FLUE GAS TEMPERATURE PROBE ALARM

Occurs when the flue gas probe is faulty. The stove goes into the alarm state and the alarms LED lights up (alarm LED on). The stove display will show the message **Al 2 alar al 2 Flue gas probe** "AL 2 ALAr AL2 ProBE EXHAuSt" (see Fig. 24) and will shut down.



Fig. 26 - Display: AL 2

11.12 FLUE GAS OVERTEMPERATURE ALARM

Occurs when the flue gas probe detects a temperature higher than a fixed set value that cannot be changed via parameter. The display will show the message **Al 3 alar al 3 Hot flue gas** "AL 3 ALAr AL3 Hot EXHAuSt" as in (see Fig. 25) and the stove will shut down.



Fig. 27 - Display: AL 3

11.13 FAULTY FLUE GAS ENCODER ALARM

It occurs if there is a fault in the flue gas fan. The stove goes into the alarm status and the message **Al 4 alar al 4 Faulty extractor** "AL 4 ALAr AL4 FAn FAiLurE" will scroll on the display (see Fig. 26).



Fig. 28 - Display: AL 4

11.14 FAILED IGNITION ALARM

It occurs when the ignition phase fails.

The message **Al 5 alar al 5 Failed ignition** "AL 5 ALAr no LiGHtin" scrolls on the display and the stove goes into alarm status (see Fig. 27).



Fig. 29 - Display: AL 5

11.15 NO PELLET ALARM

It occurs when in the working phase, the flue gas temperature drops below a specific fixed parameter.

The message **Al 6 alar No pellet** "AL 6 ALAr MAnCAno PELLEt" scrolls on the display and the stove goes into alarm status (see Fig. 28).



Fig. 30 - Display: AL 6

11.16 THERMAL SAFETY OVERHEATING ALARM

Occurs when the general safety thermostat detects a temperature above the trigger threshold. The thermostat triggers and turns off the feed screw, indicating the alarm status (alarm LED on).

The display will show the message **Al 7 alar 7 Thermal safety** "AL 7 ALAr SAFETy tHErMAL" (see Fig. 29) and the stove will shut down.



Fig. 31 - Display: AL 7

11.17 NO NEGATIVE PRESSURE ALARM

It occurs when the external pressure switch component detects a pressure/negative pressure lower than the trigger threshold. The pressure switch triggers and turns off the feed screw, indicating the alarm status (alarm LED on).









The display will show the message **Al 8 alar al 8 No Negative Pressure** "AL 8 ALAr FAiLurE dEPRESS" (see Fig. 30) and the stove will shut down.

























Fig. 32 - Display: AL 8

11.18 ALARM ALERTS

Whenever an operating condition other than that designed for the regular operation of the boiler occurs, there is an alarm condition. The control panel gives information on the reason of the alarm in progress.

ALARM	CAUSE	SOLUTION	INTERVENTION
AL 1 - BLACK OUT	Power cut during ignition phase.	Clean the burning pot and switch the stove on again.	
AL 2 - EXHAUST PROBE	Disconnected fume temperature probe	Have the stove checked.	
	Faulty fume temperature probe	Replace the fume probe.	
AL 3 - HOT EXHAUST	Faulty fume probe	Replace the fume probe.	
	Faulty mother board	Replace the electronic board.	
	The exchanger fan does not work	Replace the ambient fan.	
	Too high pellet drop value	Adjust the pellet loading.	
AL 4 - FAN FAILURE	Faulty protection fuse of the fume fan	Replace the fuse (1,25A).	
	Faulty fume fan	The pellets can burn also thanks to the chimney flue depression and without the aid of the fume fan. Have the fume fan replaced immediately. It can be noxious to health to let the stove running without fume fan.	

ALARM	CAUSE	SOLUTION	INTERVENTION
AL 5 - FAILED IGNITION	Empty hopper	Fill the hopper.	
	The burning pot has not been cleaned	Clean the burning pot.	
	The ignition threshold has not been reached	Clean the burning pot and switch the stove on again.	
	Faulty ignition plug	Replace the ignitor resistance.	
	Too sever external temperature	Start the stove up again.	
	Humid pellet	The pellets must be stored in a dry place. Please check it.	
	Blocked thermal probe	Replace the thermal probe.	
	Faulty mother board	Replace the mother board.	
AL 6 - NO PELLETT	Empty hopper	Full the hopper.	
AL 7 - THERMAL SAFETY	Boiler overheating	Let the stove cooling. (If the problem persits please call an Authorized Technician).	
	The ambient exchanger fan does not work	Replace the ambient fan.	
	Temporary power cut	The lack of tension during the running implies the overheating of the boiler and the intervention of the manula reset thermostat. Let the stove cooling, reset and start the stove up again.	
	Faulty manual reset thermostat	Replace the manual reset thermostat.	
	Faulty mother board	Replace the mother board.	

ALARM	CAUSE	SOLUTION	INTERVENTION
AL 8 - FAILURE DEPRESS	Obstructed exhaust	The exhaust chimney is partially or totally obstructed. Call an expert stove-repairer who executes a check from the exhaust up to the chimney pot.	
	Fume fan out of order	The pellet can burn also thanks to the chimney flue depression without the aid of the fan. Have the fume fan immediately replaced. It can be noxious to health to let the stove running without fan.	
	Obstructed connecting nozzle	Clean the connecting nozzle.	
	Faulty pressostat	Replace the pressostat.	
	Faulty electronic board	Replace the mother board.	
	Extreme chimney length	Contact an expert stove repairer and check that the exhaust chimney is in compliance with regulations	
	Advers whether conditions	In case of strong wind there can be a negative pressure to the chimney. Check and switch the stove on again.	
	The fire door is not correctly closed	Close the fire door correctly and check if the gaskets are broken.	
	Fire door microswitch faulty or out of order	Replace the fire door microswitch.	

11.19 ALARM RESET

To reset the alarm you must keep the P3 button pressed for some time. The stove performs a check to determine whether the warning cause is still present.

If this is the case, the warning will be shown again, otherwise the stove will switch to the **OFF** "off" position.

If the warning is still present, contact a service centre.

12 ROUTINE MAINTENANCE

12.1 INTRODUCTION

For a long working life of the stove, have a periodic cleaning of the stove as described in the following paragraphs.

- Fume outlet pipes (fume conduit + chimney flue + chimney pot) must always be cleaned, scrubbed and checked by an authorized technician in compliance with local regulations, with the instructions of the manufacturer and those of your insurance company.
- If there are no local regulations and no instruction from your insurance company, it is necessary to have your fume pipe, chim-

- ney flue and chimney pot cleaned at least once a year.
- It is also necessary to have the combustion chamber, motors and fans cleaned and to have the gaskets and the electrical elements checked at least once a year.



All these operations must be planned in time with your Authorized Technical Assistance Service.

- After a long ineffective time, before turning on the stove check if there are obstructions in the fume exhaust.
- If the stove had been using continuously and intensely, the whole system (chimney included), must be cleaned and checked more frequently.
- In case of replacement of damaged pieces please ask for the original spare part at the Authorized Retailer.

12.2 DAILY OR WEEKLY CLEANING PERFORMED BY THE USER

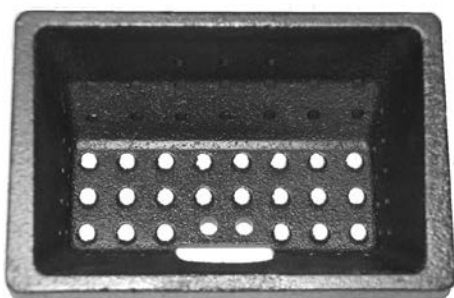

Fig. 33 - Example of a clean brazier

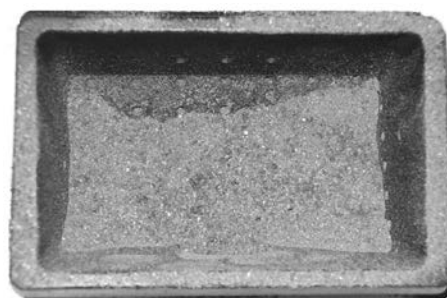

Fig. 34 - Example of a dirty brazier

12.3 BEFORE EACH START-UP

Clean the ash and any deposits in the brazier that could clog the air passage holes.

If the pellets in the hopper finish, unburned pellets may accumulate in the brazier. Always empty the residue in the brazier before starting up.

Check that there is no excessive ash accumulated under the burning pot compartment. If it exceeds 2 cm of height, we recommend sucking it.



REMEMBER THAT ONLY A CORRECTLY POSITIONED AND CLEAN BRAZIER CAN GUARANTEE START-UP AND OPTIMAL OPERATION OF YOUR PELLET PRODUCT.

For the brazier to be cleaned properly, remove it from its housing completely and thoroughly clean all the holes and the grate on the bottom.

If good quality pellets are used, you will normally only need to use a brush to restore the optimal operating conditions of the component.

12.4 HOPPER AND AUGER CLEANING

Per each pellets supply, check the probable presence of meal, sawdust and other remainins on the hopper bottom. If present, they must be removed with the aid of a vacuum cleaner (see **Fig. 33**).



Fig. 35 - Hopper and auger cleaning

12.5 FUME PIPES ANNUAL CLEANING



Clean annually from soot with brushes.

The cleaning operation must be executed by a specialized stove-repairer who will provide for the cleaning of fume pipe, chimney flue and chimney pot. He will also check their efficiency and will release a written declaration of the safety of the appliance. This operation must be executed at least once a year.

12.6 GENERAL CLEANING

For cleaning external and inner parts of the stove do not use steel wools, muriatic acid or other corrosive and abrasive materials.

12.7 CLEANING OF PAINTED METAL PANELS

To clean painted metal panels use a soft cloth. Do not use degreasant agents like alcool, diluents, acetone, gasoline because these could irremediably damage the varnish.

12.8 GLASS CLEANING

The glass-ceramic of the fire door is able to stand till 700°C but not to thermal shocks.

The probable cleaning with usual sale product for glass cleaning must be effected at cool glass in order to avoid explosions.



You should clean the fire door glass every day!

13 IN CASE OF ANOMALY











13.1 PROBLEM SOLVING





















Before of every Authorized Technician intervention, the same Technician has the duty to check if the parameters of the mother board correspond to those of the table you own.



In case of doubts regarding the use of the stove, please contact ALWAYS the Authorized Technician on order to avoi irreparable damages!

PROBLEM	CAUSE	SOLUTION	INTERVENTION
The control display does not switch on	The stove is without power supply	Check if the plug is connected.	
	Burned protection fuse in the electric socket	Replace the protection fuses in the electric socket (3.15A-250V).	
	Faulty control display	Replace the control display.	
	Faulty flat cable	Replace the flat cable.	
	Faulty electronic board	Replace the mother board.	
Pellets do not reach the combustion chamber	Empty hopper	Full the hopper.	
	Open fire door or open pellet door	Close fire door and pellet door and check that there are no pellet grains at the gasket level.	
	Clogged stove	Fume chamber cleaning	
	Auger blocked by a foreign object (for example nails)	Clean the auger.	
	The auger geared motor is out of order	Replace the geared motor.	
	Check if on the display there is an active alarm	Have the stove checked.	

PROBLEM	CAUSE	SOLUTION	INTERVENTION
The fire extinguish and the stove stops	Empty hopper	Full the hopper.	
	Auger blocked by a foreign object (for example nails)	Clean the auger.	
	Bad quality pellets	Try other types of pellets.	
	Pellet drop value too low "phase 1"	Adjust the pellet loading.	
	Check if on the display there is an active alarm	Have the stove checked.	
Flames are weak and orange coloured, pellets do not burn properly and the glass blackens	Not sufficient combustion air	Check as following: probable obstructions of the combustible air inlet from the back or from the bottom of the stove; burning pot obstructed holes with too ash remains. Have the fan blades and auger cleaned.	
	Obstructed exhaust	The exhaust chimney is partially or totally obstructed. Contact an expert stove-repairer who checks the stove from the exhaust up to the chimney pot. Provide immediately for stove cleaning.	
	Obstructed stove	Provide immediately at the inner cleaning of the stove.	
	The fume fan is out of order	The pellets can burn also thanks to chimney flue depression without the aid of the fume fan. Have the fume fan immediately replaced. It can be noxious to health to let the stove running without fume fan.	
The exchanger fan continues to turn even though the stove has just cooled	Faulty fume temperature probe	Replace the fume probe.	
	Faulty mother board	Replace the mother board.	
Ash remains along the stove	Faulty or out of order door gaskets	Replace the gaskets.	
	Not sealed fume pipes	Contact an expert stove-repairer who will immediately provide for sealing the junctions with high-temperature silicone and/or for replacing pipes with those in compliance to current regulations. A not sealed fume channelisation can be noxious to health.	

PROBLEM	CAUSE	SOLUTION	INTERVENTION
The stove is at its highest power but does not heat up.	Ambient temperature reached.	The stove is at its minimum value. Increase the desired ambient temperature.	
Stove running and display showing HOT EXHAUST "Hot EXHAuSt"	Reached fume outlet limit temperature	The stove runs at minimum. NO PROBLEM!	
The stove's smoke duct produces condensation	Low smoke temperature	Check that the flue is not clogged.	
		Increase stove power to minimum (pellet drop and fan revs).	
		Install condensation collection cup.	
Stove running and display showing SERVICE "SErVicE"	Routine maintenance alert (it does not block the system)	When this flashing message appears upon start-up, it means that the preset operating hours have elapsed before maintenance. Contact the service centre.	

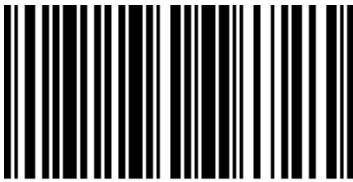

89019047A

Rev. 00 - 2022

CADEL srl
31025 S. Lucia di Piave - TV
Via Foresto sud, 7 - Italy
Tel. +39.0438.738669
Fax +39.0438.73343

www.cadelsrl.com
www.free-point.it
www.pegasoheating.com